



FINISHING

GTEC Taping and Jointing provides a finish to joints between GTEC boards creating a continuous, fire resistant and easy to decorate surface. Skimming can achieve similar results but is a more labour and time intensive method. Tiling GTEC moisture and wet area GTEC boards can achieve exceptionally high levels of water resistance.

GTEC Cove is a decorative gypsum element used to finish the junction between partition and ceiling.

GTEC Taping and Jointing	278
Alternative finishing methods	284
GTEC Cove	288

GTEC® TAPING AND JOINTING

GTEC drywall systems require taping and jointing to complete the wall surface, reinforce joints to prevent cracking, and ensure fire and sound performances are achieved.

GTEC Taping and Jointing products use limited combustibility, gypsum and limestone based compounds which secure the fire rating of the system. These are reinforced with paper tape or corner beads to create a smooth, durable surface, ready for decoration. Two and three stage processes are available using the correct GTEC Finish products to provide options on site and different setting times.

Water resistant compounds and finishing accessories are available for GTEC Aqua Board. The GTEC Deco compound range complements the use of GTEC Megadeco for direct decoration.

WHERE TO USE:

- ▶ Taping and jointing are suitable for large surface areas where speed and ease of application can greatly reduce installation cost and drying time.

FEATURES	BENEFITS
Applied to low surface areas	Quicker than a full plaster skim with less drying out time
Can be used with automatic taping tools	Flexible, high speed application
Can be hand applied	Versatile enough to suit any job
Wide product range	Suitable for different applications and needs
Gypsum/limestone finish	Excellent finish quality with limited combustibility
Two and three stage processes	Provides a range of speed and product options

SYSTEM COMPONENT TABLE

System Component	System primary use
BOARDS	
	All GTEC Boards (see specialist compounds for Aqua & Megadeco) Provides wall surface suitable for finishing.
FINISHING	
	GTEC Joint Filler Xtra Gypsum based joint compound for filling joints in plasterboards, 90 minute set time
	GTEC Joint Cement Xtra Air-drying joint cement for finishing joints
	GTEC Easy Finish Extra All purpose compound suitable for all stages of the jointing process with 90 minute set time
	GTEC Smartmix Ready mixed all purpose jointing compound suitable for all stages of the jointing process
	GTEC Aquamix Ready mixed all purpose jointing compound for use with GTEC Aqua system in severe wet applications
	GTEC Deco Filler An all purpose gypsum based joint filler for use with GTEC Megadeco. 90 minute set time
	GTEC Deco Joint Cement An air drying ready mixed compound for finishing joints with GTEC Megadeco
	GTEC Deco Machine An air drying ready mixed compound for use with automatic taping tools to finish joints with GTEC Megadeco
	GTEC Joint Tape Joint reinforcement in conjunction with GTEC Jointing Compounds
	GTEC Aquastrip Mesh tape for use with GTEC Aqua system to protect exposed drylining perimeters for wet applications
	GTEC Sealers To seal plasterboard prior to decoration
	GTEC Corner and Edge beads Corner and edge reinforcement

SYSTEM GUIDANCE

COMPOUND SELECTION

Joint compound selection is largely a matter of site preference, depending on weather conditions, time and equipment. GTEC Compounds can be combined in numerous permutations each offering a high quality surface finish. However, GTEC Aqua Board and

GTEC Megadeco require specific compounds to suit their unique facers.

Taping and jointing is conducted in three main stages: Bedding; Second Coat; and Finishing Coat.

TWO STAGE PROCESS

THREE STAGE PROCESS

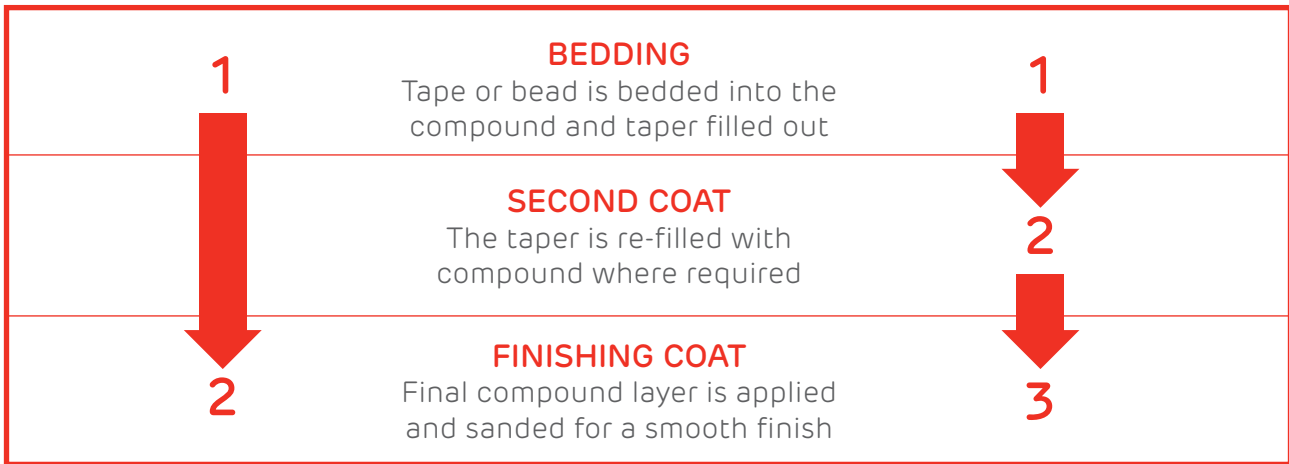

COMPOUND TYPES

- ▶ All compounds are suitable for Bedding and Second Coat, however, setting and hybrid compounds reduce overall time required.
- ▶ Setting and hybrid compounds must not be used over air-drying compounds.
- ▶ Only air-drying or hybrid compounds are suitable for the final finishing coat.
- ▶ Air-drying and hybrid compounds are low shrinkage. Where low shrinkage compounds have been used in Bedding layer the Second Coat may not be required.
- ▶ The drying time of air-drying compounds is dependent on climatic conditions and layer thickness. Drying takes approximately 24 hours but may be extended by adverse conditions.

GTEC Compound	Format	Type	Compatible Boards	Machine Use	Shrinkage	Setting Time
Joint Filler Xtra	Powder	Setting	All	No	Standard	90 mins
Joint Cement Xtra	Powder	Air-drying		Yes	Low	n/a
Smartmix Xtra	Readymix	Air-drying	optional	Yes	Low	n/a
Easy Finish Xtra	Powder	Hybrid	optional	No	Low	90 mins
Aquamix	Readymix	Air-drying	GTEC Aqua Board	Yes	Standard	n/a
Deco Filler	Powder	Setting	GTEC Megadeco only	No	Standard	90 mins
Deco Joint Cement	Readymix	Air-drying		No	Low	n/a
Deco Machine	Readymix	Air-drying		Yes	Standard	n/a

SUBSTRATE

- ▶ Plasterboard to be tapered edged to allow GTEC Joint Tape to sit below finished surface for best finish. Square edged plasterboard may also be jointed following guidance in drawings.
- ▶ Board surfaces to be dry, clean, protected from weather, secure and evenly fixed.
- ▶ Correct screw fixings to be used with screw heads just below surface of board.
- ▶ Gaps over 3mm to be filled with GTEC Joint Filler Xtra or GTEC Easy Finish.
- ▶ Taping & jointing should not be carried out at extreme temperatures (greater than 40°C or less than 5°C). Do not tape and joint on frozen backgrounds.

TAPING & JOINTING

FN-TJ-101&102M – Tapered edge

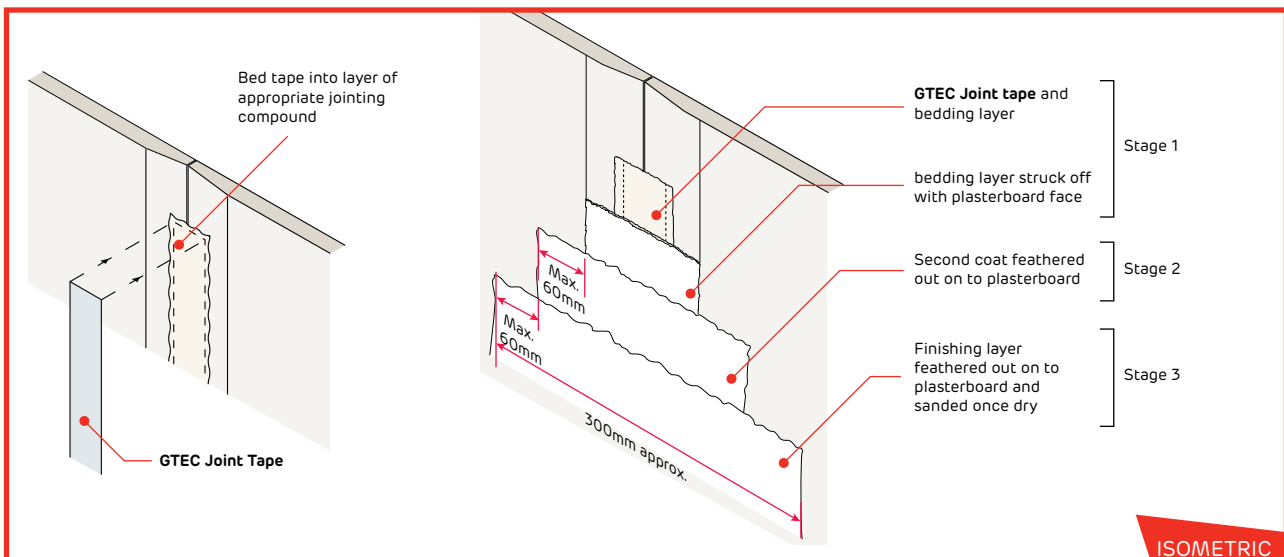

FN-TJ-103&104M – Square or cut edge

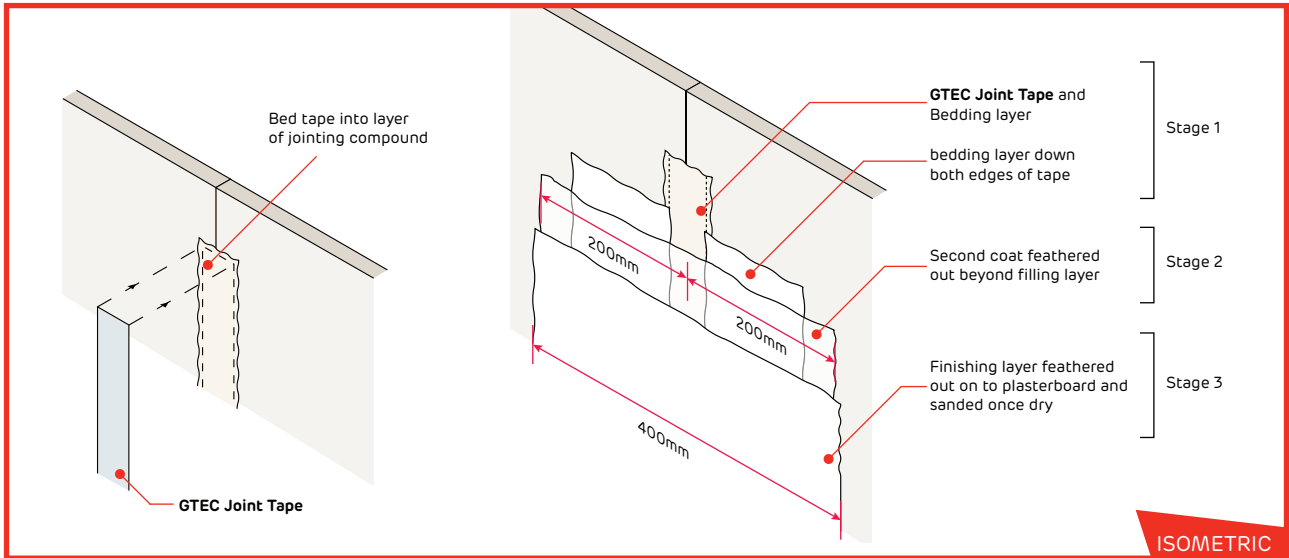

FN-TJ-105 & 106M – Internal corner

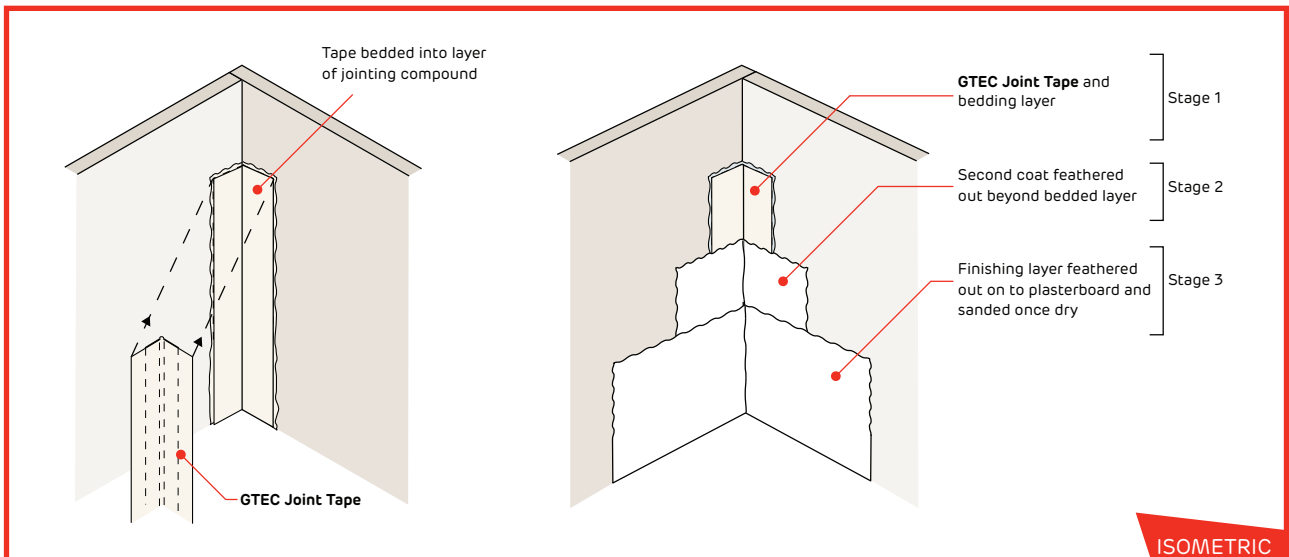

FN-TJ-107&108M – External corner

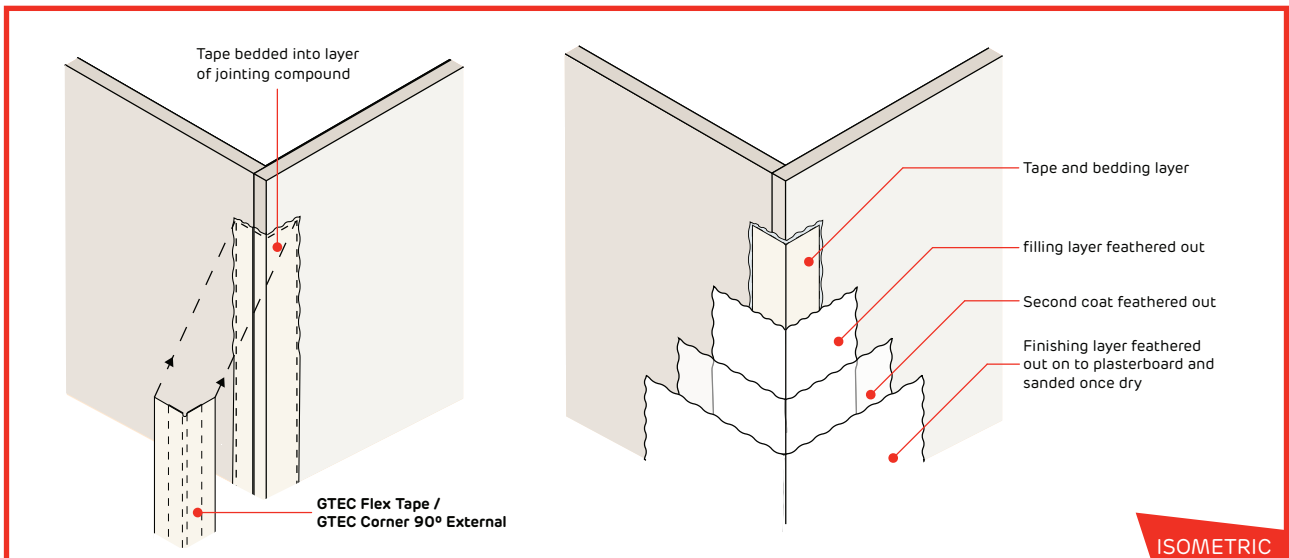

- ▶ Screws to be spotted with appropriate jointing compound.
- ▶ Compound to be applied in nominal 1mm layers. Thicker layers will extend drying out time.
- ▶ GTEC Joint Tape cut to length to be pressed into bedding compound without trapping air bubbles, bedding layer of compound to be flush with plasterboard face. Pound to be flush with plasterboard face.
- ▶ Second coat of jointing compound if required to be applied over dry joint, feathered out 50-60mm beyond the edge of first coat. Second coat to be set hard or dry prior to third stage.
- ▶ Finishing coat of compound feathered out 50-60mm beyond second coat. Finished, dry joint to be sanded to smooth finish for sealing and decoration.

Square edge joints only:

- ▶ Joint width to be wider to reduce visible crowning.

External corners only:

- ▶ GTEC Flex Tape to be applied in place of GTEC Joint Tape as reinforcement.

Machine application:

- ▶ Air-drying compounds only to be used in automatic taping machines.
- ▶ Setting compounds such as GTEC Joint Filler or GTEC Allset Xtra are not suitable for automatic taping machines.

High and Severe Moisture Exposure:

- ▶ GTEC Aquamix compound to be used in high and severe moisture/humidity exposure areas.
- ▶ In areas of severe moisture exposure GTEC Aqua Board to be coated with two layers of GTEC Drywall Sealer.

DECORATION

- ▶ Surfaces and joints to be dry prior to finishing.
- ▶ Joint to be sanded smooth for decoration. Surfaces to be dust free prior to sealing.
- ▶ Seal with GTEC Universal Sealer prior to paint application to improve whiteness and paint coverage. GTEC Megadeco Boards and GTEC Deco joints together do not require sealing.
- ▶ Two coats of GTEC Drywall Sealer can provide 15 MNs/g vapour barrier.
- ▶ Paint to be applied in accordance with manufacturer's instructions to dry and dust free surface.

SKIMMING

A traditional skimming plaster finish provides a surface ready to be decorated and is an alternative to GTEC Taping and Jointing in certain applications. It is particularly suitable where the quality of board installation is poor, as it will cover surface imperfections, and where drying out time is not important.

Most GTEC Boards are designed to accept skim plasters.

SYSTEM GUIDANCE

APPLICATION

- ▶ Skim plaster can be applied by hand or machine.
- ▶ Refer to skim plaster manufacturer's instructions for application details.
- ▶ Moisture resistant GTEC Boards (GTEC MR range and GTEC LaDura) to be pre-treated with bonding agent by others.
- ▶ Board to be clean of dust, dirt and grease, and sufficiently true to allow the specified thickness of plaster.

FINISHING

- ▶ Skim plaster to be allowed to dry out thoroughly before decoration or tiling is started.
- ▶ Paint manufacturer's instructions should be followed for decorating to new plaster.

GTEC Board	Suitable for Skim	Pre-treatment
Standard Board	Yes	None
Plank	Yes	None
Contour	Yes	None
Base Board	Yes	None
Vapour Board	Yes	None
Vapour Base Board	Yes	None
Moisture Board	Yes	Bonding agent
Fire Board	Yes	None
Fire MR Board	Yes	Bonding agent
Fire V Board	Yes	None
Fire Core Board	Yes	Bonding agent
E Board	Yes	None
dB Board	Yes	None
Acoustic Homespan	Yes	None
Acoustic Homespan MR	Yes	Bonding agent
Megadeco	No	n/a
Universal Board	Yes	None
Thermal	Yes	None
Thermal XP	Yes	None
Thermal K	Yes	None
LaDura	Yes	Bonding agent
Aqua Board	No	n/a
Render Board	No	n/a

TILING

Internal dry-lined surfaces are suitable for tiling in a wide variety of applications in both domestic and commercial applications including showers, toilets and bathrooms as well as permanently wet areas such as swimming pools.

Ceramic tiling can be applied to GTEC Aqua, LaDura and Moisture Boards for use in wet, moist or humid areas. Tiling can be applied to any board if the area is generally dry, such as decorative tiles in a corridor.

Vertical frame centres for linings and partitions to be determined by system height and tile weight.

Advice in the subsequent section is for low, medium, high and severe humidity applications.

	Normal conditions	Low to Medium Humidity	High to Severe Humidity
GTEC Board	General internal applications	Washrooms, toilets, kitchens, bathrooms	Swimming pool, spa, wet rooms, public showers
Aqua Board	✓	✓	✓
Moisture Board	✓	✓	✗
LaDura	✓	✓	✗
All other boards	✓	✗	✗

FN-TL-001M 'Low to High Humidity'

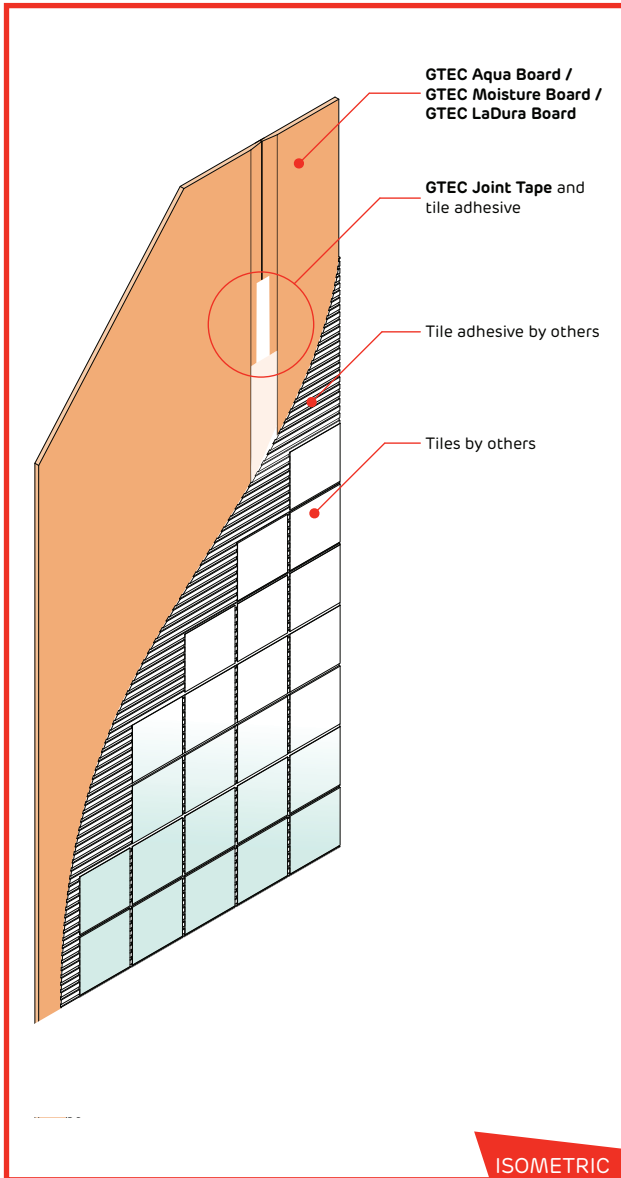

FN-TL-002M 'Severe Humidity'

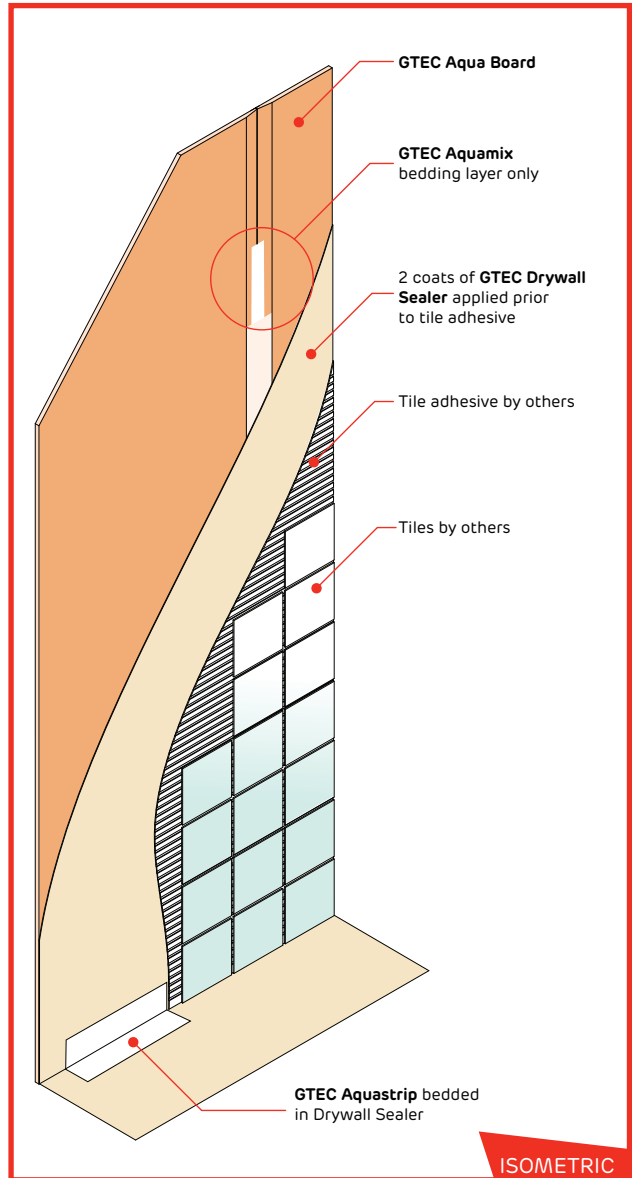

SYSTEM GUIDANCE

SUBSTRATE

- ▶ All surfaces to be clean and dust free with all loose material removed.
- ▶ Where primer is recommended follow manufacturer's instructions.

BONDING

- ▶ Tiles to be fixed in accordance with BS 5385.
- ▶ Ceramic, glazed and stone tiles to be fixed directly to board using waterproof adhesive which is suitable for plasterboard substrates.
- ▶ Tiles not to exceed maximum weight per metre depending on board type.
- ▶ Maximum weight of tiles by type of board at 400mm stud centres:

Maximum weight of tiles*	
GTEC Moisture Board	32kg/m ²
GTEC LaDura Board	32kg/m ²
GTEC Aqua Board	36kg/m ²

*for greater tile weight please contact Technical Enquiryline for recommendations

BOARDING

- ▶ Untiled areas to be taped and jointed, see GTEC Taping and Jointing section, p278.
- ▶ Taper edge boards to be used to enable formation of flush joints in untiled areas and to ensure flat substrate for tiling.
- ▶ Drylining systems using GTEC Universal Bonding Compound in their construction to be allowed 10 days to achieve full strength before tiling.

FINISHING

- ▶ For concealed joints only GTEC Joint Tape may be bedded with waterproof, ceramic tile adhesive. Untiled areas to be taped and jointed using GTEC Aquamix.
- ▶ In severe humidity areas tiles to be finished with suitable waterproof tile grout and sealed if required.
- ▶ Details at junctions, corners and perimeters to be designed to prevent moisture penetration.
- ▶ Seal around pipes, baths, shower fittings, openings and outlets with waterproof silicone sealant.
- ▶ In areas of severe humidity GTEC Drywall Sealer with GTEC Aquastrip to be used to protect base of partition/lining.

GTEC® COVE

GTEC Cove provides a decorative feature to the ceiling and wall junction, masking unsightly cracks and improving the acoustic mass and sealing along the junction.

GTEC Cove is made from gypsum encased in a profiled and strong paper liner, available in two sizes, 90 and 120mm. It is bonded to the wall and ceiling using GTEC Cove Adhesive and it is easy to work with, rigid and provides an excellent surface for decoration.



WHERE TO USE:

- Used in domestic new build or renovation projects to complement the wall and ceiling junction.

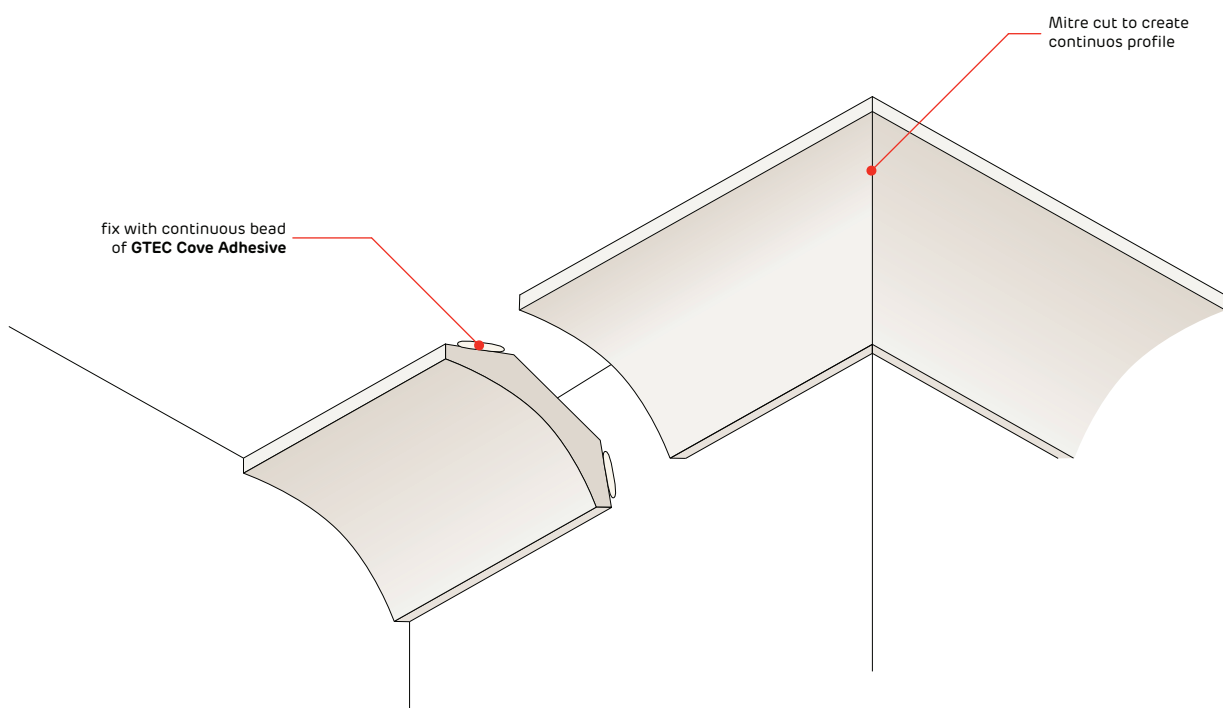
FEATURES	BENEFITS
Flat rear profile	Easy to fix
Decorative shape	Distinctive feature
Gypsum product with paper finish	Easy to decorate and lightweight



SYSTEM COMPONENT TABLE

System Component	System primary use	Product Reference
COVE		
	GTEC Cove Gypsum plaster moulding used to finish the junction of walls and ceilings	n/a
FIX		
	GTEC Cove Adhesive Gypsum based adhesive, 40 minute setting time for fast fixing of cove	n/a
FINISH		
	GTEC Universal Sealer Use prior to painting to improve brightness and coverage	n/a

SYSTEM GUIDANCE

COVING

FN-CV-101S – Cove 90 and 120

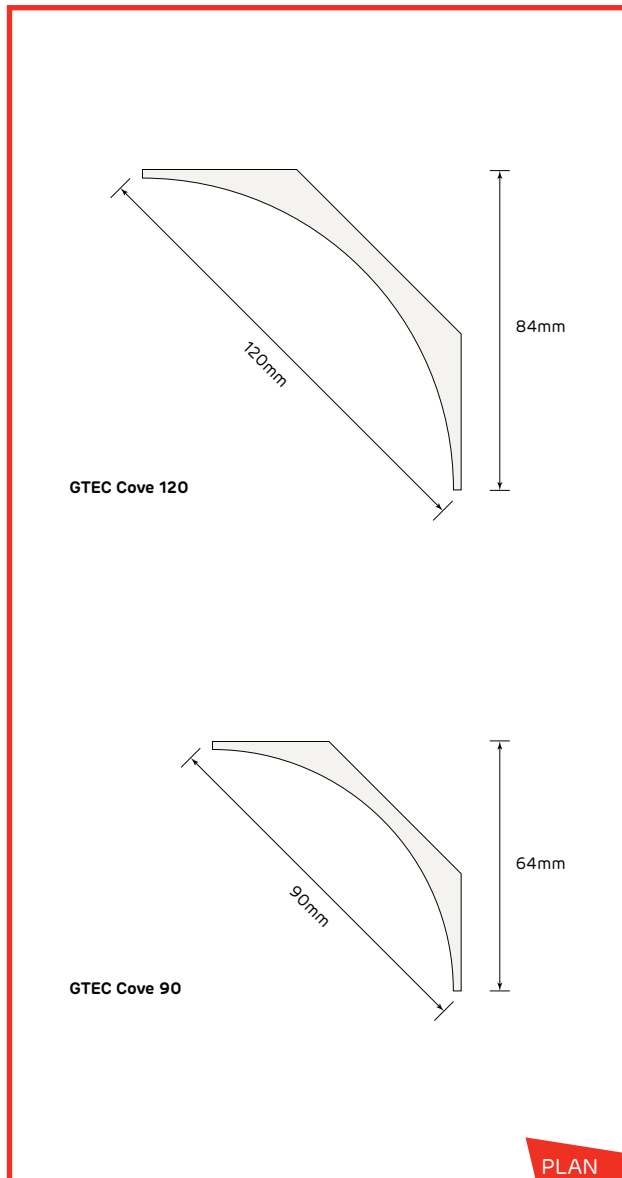

- ▶ Substrate to be dry, rigid and dust free, with any wallpaper, whitewash or loose decoration removed.
- ▶ Surfaces which have been previously painted to be abraded and coated bonding agent.
- ▶ Nails to be installed below cove location and at 1500mm centres to act as temporary support while cove adhesive sets.
- ▶ GTEC Cove Adhesive to be applied in 3mm thick and 10mm wide beads along full length of each edge of GTEC Cove.
- ▶ GTEC Cove Adhesive to fill any gaps between cove and wall or ceiling.
- ▶ With uneven ceilings it may be necessary to permanently nail cove 25mm from one edge. Nail heads should be countersunk and covered with GTEC Cove Adhesive.
- ▶ Ensure temperature does not fall below 5°C.

FINISHING

- ▶ Coat of GTEC Universal Sealer to be applied to enhance paint coverage and finish.
- ▶ Plasterboard strips may be added between coving and ceiling to add extra stepped features. Visible edges of plasterboard strips to be bound edges for decoration.

